



# INSULATED ROLLING STEEL DOORS MODEL 400



## SPECIFICATIONS

**FURNISH** Insulated Rolling Service Doors, series 400 as manufactured by "ADT" complete with curtain, hood, guides, counterbalance and options as specified.

### OPERATION

- chain hoist using gear reduction and hand chain
- external industrial motors

**CURTAIN** consists of interlocking IS3 thermal slats cold rolled formed from galvanized steel baked on grey polyester enamel coating or 304 stainless steel with a #4 finish. Each end of alternate slats are to be assembled with polycast nylon end locks to maintain slat alignment and to act as a wearing surface inside the door guides and reduce noise from metal to metal contact. Slat thickness shall be calculated with U.S. gauging with a minimum of 20ga. for doors up to 30'0" wide and 18ga. for wider spans. The interlocking 24 gauge protective back slat encloses the insulating core reducing heat and sound transmission. Steel slats are to be galvanized as per A.S.T.M. A653. Each curtain shall receive a bottom bar to maintain slat alignment and posture.

**INSULATION** shall consist of closed cell urethane foam injected insulation a minimum of 1" thick, providing a 7.2 R-value and sound barrier protection with a STC 25 rating. Insulation is pressure foamed in place bonding the both front and back slats while filling all voids and creating a thermal break.

**BOTTOM BAR** shall consist of two steel factory painted angles a minimum 1/8" thick. Includes rubber astragal to form a weathertight seal, on a level surface, upon closing service door.

**SPRING COUNTERBALANCE** is to be housed in a steel pipe of the appropriate diameter and wall thickness as to support curtain. Deflection shall be limited to a maximum of .03" per ft. of door width. Springs are to consist of helical torsion type designed to meet a 25% safety load factor. Safety factor allows for safe operation, ease of use, and longer spring life. Springs are to be grease packed and anchored, using a cast iron anchor, to a cold rolled steel inner shaft. Spring tension shall be fully adjustable from outside of end bracket plate. To insure smooth operation end bracket plates shall contain sealed ball bearings to minimize wear of pipe shaft.

## HIGHLIGHTS

- 8.5 R Value
- Curtain over 1" thick
- Foam Injected Insulation
- Heavy duty construction
- Torsion spring counterbalance
- Galvanized steel hood
- Thick wall 20gauge galvanized steel curtain
- Polycast<sup>®</sup> endlocks
- Double steel angle bottom bar
- Easy servicing

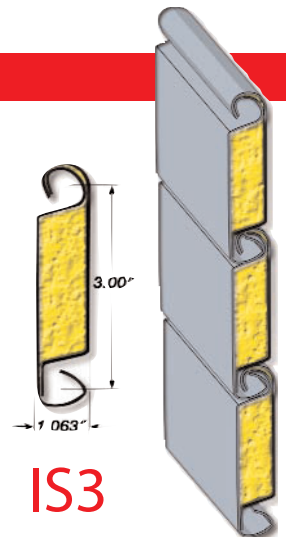

**IS3**

**END BRACKET** plates shall consist of steel plate no less than 3/16" thick. Bracket plates are to house pipe shaft and counterbalance assembly. Shaft is attached to plate by sealed ball bearings fitted onto plate.

**GUIDES** shall consist of a minimum of 3" structural steel angles a minimum of 3/16" thick. The guide depth shall be of a length adequate to provide for proper slat penetration and specified windloading. When windlocks are to be provided a windlock bar shall be furnished within guide to prevent curtain from leaving the guides under windload.

**HOODS** shall consist of a minimum of #24 gauge hot dipped galvanized steel with a baked on grey or bronze polyester enamel coating. Hoods are designed to protect and house counterbalance assembly. To prevent hood sag intermediate supports shall be furnished as required.

**FULL WEATHER STRIPPING** shall include

- Neoprene hood baffle
- Vinyl guide seals
- Neoprene astragal on bottom bar

**LOCKING** for manual and chain operated doors to be slidebolts mounted on bottom bar with provisions for padlocks. Gearing within motors to be self locking.

**FINISH** all non-galvanized surfaces shall receive a shop coat of rust inhibiting grey or bronze industrial enamel paint. Field painting not included in this section.

**INSTALLATION** to be by ADT or by an authorized dealer.

### OPTIONS

- Poly-cote<sup>®</sup> polyester powder coating, 200 select colors
- Acrylic vision lites
- High cycle springs
- Sloping bottom bar
- Pass door
- 18 gauge steel slats
- Stainless Steel Slats
- Aluminum Slats
- Safety edge
- Remote Control
- Timer to close
- Cylinder locks
- Electric interlocks
- Lintel Seals
- Malleable iron endlocks and windlocks

# CLEARANCE DETAILS 400 SERIES

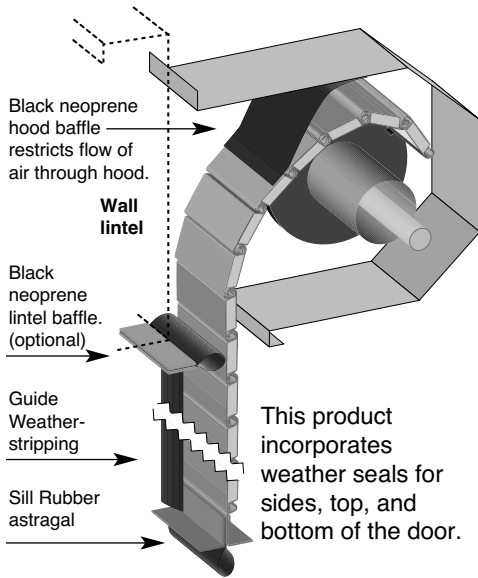

## CHAIN OPERATION

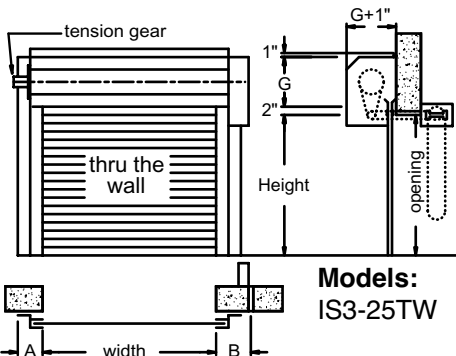
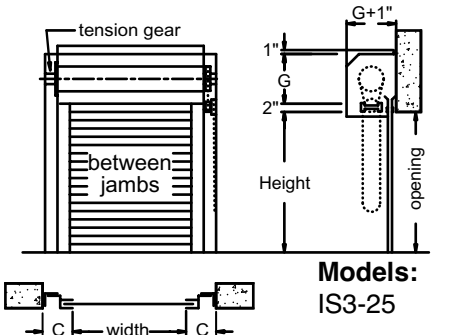
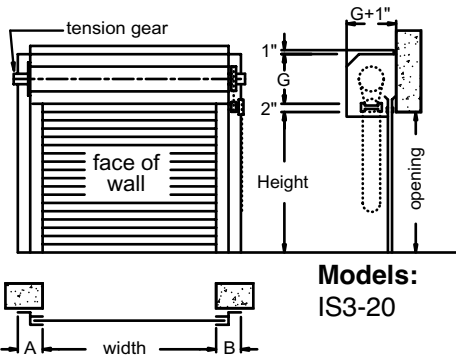

## MOTOR OPERATION

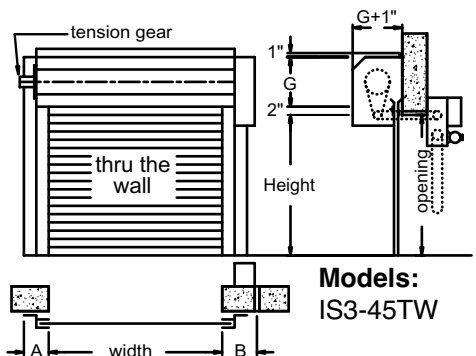
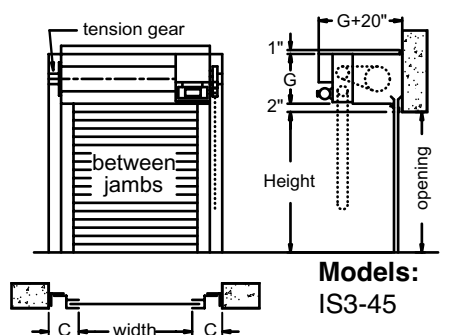
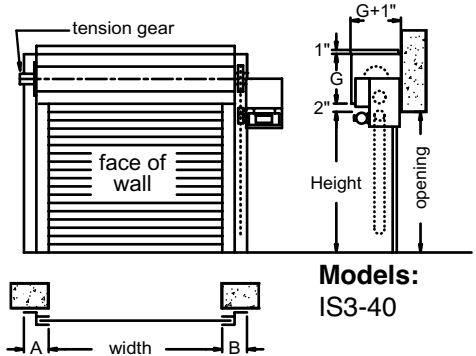

### ENERGY SAVINGS

Our insulated doors pay for themselves in less than 4 years.\*

Zone	Yearly Savings*	Payback Years
1	\$461	3.3
2	\$442	3.5
3	\$423	3.7
4	\$406	3.8

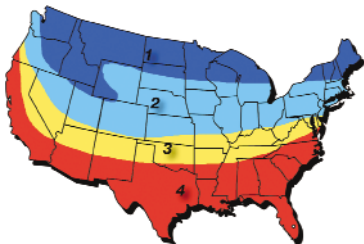

### E-MOUNT

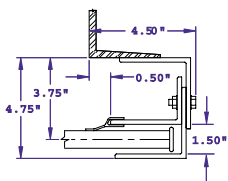

### Z-MOUNT

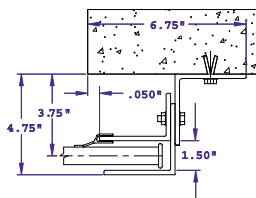

### TUBE MOUNT

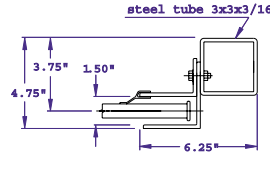

### BETWEEN THE JAMBS (CHAIN/MOTOR OPERATION)

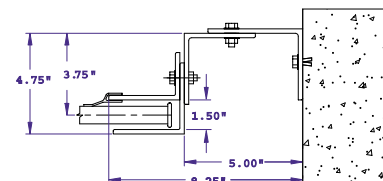

3" wide guide shown with guide seals

For fastening to steel using machine bolts or welding

For fastening to masonry using expansion bolts or through the wall threaded rod (if required.) 4" guides on spans over 22'4" or with windlocks. Where clearances are critical, dimensions may be reduced. Refer inquiries to our Engineering Department.

### CURTAIN FINISH

- GS** Galvanized steel
- PS** Gray Polyester enamel on galv. steel
- SS** Stainless steel

### STANDARD LOCKING



HEIGHT	G	G windlocks
up to 6'8"	16"	16"
6'9" up to 8'3"	17"	17"
8'3" up to 9'11"	18"	18"
10'0" up to 11'8"	19"	19"
11'9" up to 13'5"	20"	20"
13'6" up to 15'2"	21"	21"
15'3" up to 17'2"	22"	22"
17'3" up to 19'2"	23"	23"

WIDTH	A	B	C	D
to 22'4"	6.75"	9.25"	8.75"	3.875"
22'4" to 28'4"	7.75"	10.75"	9.25"	N/A
over 28'4"	consult factory			

**ADVANCED DOOR TECHNOLOGY**  
 34 N. Crystal Street, East Stroudsburg PA 18301  
 (570) 421-5929  
<http://www.adtdoor.com>